

FN	PART NUMBER	DESCRIPTION
01	F1471-H	FILTER HEAD
02	F1471-B	FILTER BOWL
03	F1077-E100	ELEMENT, FILTER
04	4010-026T0	O-RING, TEFLON SZ 026
05	4010-152T0	O-RING, TEFLON SZ 152
06	4011-152T	BACK-UP RING, TEFLON SZ 152
07	F071-ES	ELEMENT SPACER
08	F1076-EC	ELEMENT CAP
09	4010-036T0	O-RING, TEFLON SZ 036 (2X)

NOTES:

- LUBE ALL O-RINGS, O-RING SEAL SURFACES, THREADED CONNECTIONS WITH AN OXYGEN COMPATIBLE LUBRICANT (CHRISTO-LUBE MCG-111 OR EQUAL).
- TORQUE REQUIREMENTS:
BONNET TO BODY 150 FT-LBS

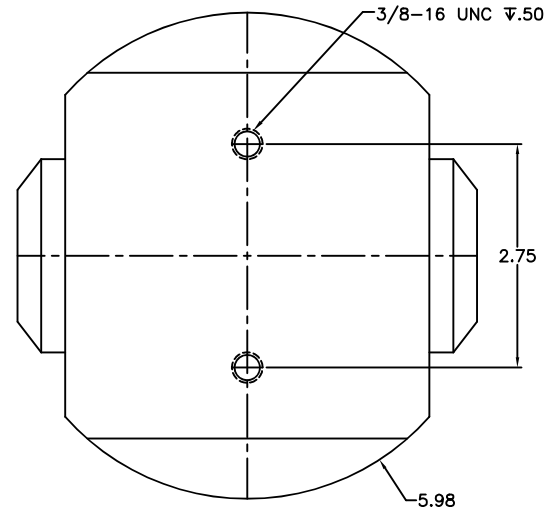

TOP VIEW

TEE TYPE FILTER ASSEMBLY
MONEL HOUSING / BRONZE FILTER

6000 PSIG MAX PRESSURE
 PROOF PRESSURE 150%
 PRESSURE RATING PER ASTM B31.3
 2" SCHD XX PIPE STUBS
 100 MICRON BRONZE SINTERED ELEMENT
 TEFLON SEALS
 MONEL/BRASS CONSTRUCTION
 CLEAN FOR OXYGEN SERVICE PER ASTM G93

NOTE: ELECTRO-ETCH
 FLOW ARROW AND LOT
 CODE ON HEAD BEFORE
 SHIPPING

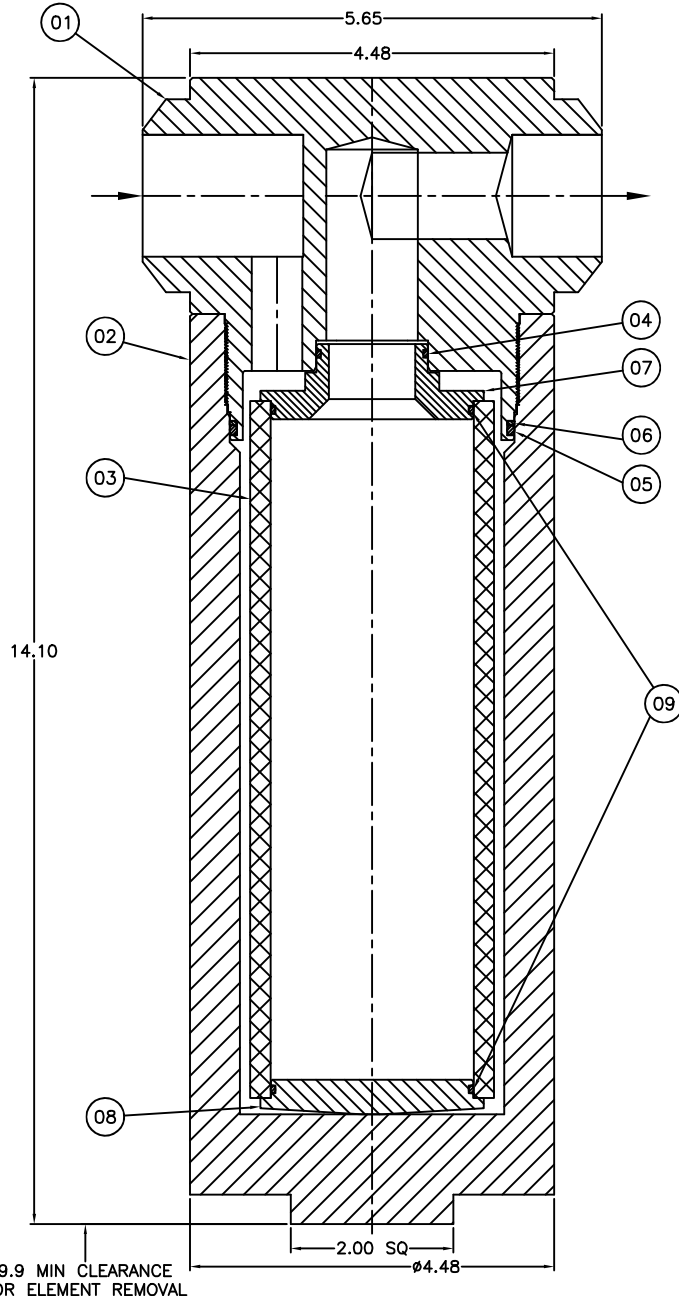

9.9 MIN CLEARANCE
 FOR ELEMENT REMOVAL

REV.	DATE	CHG BY	DESCRIPTION OF CHANGE
2	05-26-22	PTS	UPDATED ELEMENT AND SPACER P/N
1	1-25-22	TW	INITIAL RELEASE

REVISION HISTORY

MATERIAL					
FINISH					
ALL PARTS MUST BE CLEANED FOR OXYGEN SERVICE PER ASTM SPEC G93. GLOVES MUST BE WORN DURING PART HANDLING.					
UNLESS OTHERWISE SPECIFIED: 0 ± 0.2 REMOVE ALL BURRS 00 ± 0.1 DIMENSIONS IN INCHES 000 ± 0.05 ISO / ASME Y14.5 ANGLE ± 1° CORNER BREAKS 005-020 FILLET RADI 005-020 SURFACE ROUGHNESS: 32 ✓ THREADS: CLASS 2 THREAD LENGTHS ARE FULL THREAD DO NOT SCALE PRINTED DRAWING		SCALE:	DRAWN BY:	APPROVED BY:	
		TW	1-25-22	PTS	8-29-22
DESCRIPTION				PART NUMBER	
ASSEMBLY FILTER				F1471-100	
CAGE CODE		PART NUMBER		SIZE	
4FX47		F1471-100		C	
THIRD ANGLE PROJECTION		SHT. 1 OF 1			