

# FABRICATED BASKET STRAINERS

12" - 48" | ANSI CLASS 150, 300

SMALLER SIZES AVAILABLE

Fabricated Basket strainers are required when an off-the-shelf solution will not meet your exact piping requirements. All of our Fabricated Strainers are made right here in the USA, at our state-of-the-art facility in the southeastern part of North Carolina.

16" Fabricated Basket Strainer with Optional Davit Assembly shown



All pictures shown are for illustrative purposes only. Actual product may vary due to product enhancement.

## CUSTOM COVER SOLUTIONS INCLUDING DAVITS & HINGED COVER



HINGED



DAVIT



BOLTED

Sizes 2" - 48" Available

## MODELS

- FB 20 Series - 150 Class
- FB 30 Series - 300 Class

## MATERIALS:

- Carbon Steel • Stainless Steel
- Other Alloys

## OPTIONS



- Gauge Taps
- Vent/drains - (Standard)
- Back Flush Valves
- Semi-Automatic
- Pressure Gauges
- DP Gauge Switch
- Support Legs



## ANSI CLASSES

ANSI Class 150 up to high pressure 900 class



## STRAINING ELEMENTS

Customize to fit your requirements  
Heavy Duty Baskets, Wedge Wire, & Multi Basket Designs



## END CONNECTIONS

Flanged, Raised Face, RTJ, Butt Weld, Socket Weld, Threaded



## SANITARY

Sanitary Application Designs for food/pharmaceutical processing



## TEMPERATURE CONTROL

Steam Jacket casing for set temperature control



## UNIQUE PROJECTS

Rotated and Offset Nozzles to fit into your applications

**BILL OF MATERIALS**<sup>(1)</sup>  
FB 20 & FB 30 Series (Multi-Basket)

Part	FB 20 & FB 30 Carbon Steel	FB 20 & FB 30 Stainless Steel
1 Body	Carbon Steel A106 Gr.B	Stainless Steel SA312 Type 316
2 Body Flange	Carbon Steel A105	Stainless Steel SA182 Type 316
3 Cover	<b>Bolted:</b> Carbon Steel A105 <b>Quick-Open:</b> Carbon Steel A516 Gr. 70	<b>Bolted:</b> Stainless Steel SA182 Type 316 <b>Quick-Open:</b> Stainless Steel Type 316
4 Pipe Cap	Carbon Steel A234 Gr.WPB	Stainless Steel SA403 Type 316
5 Inlet/Outlet Flange	Carbon Steel A105	Stainless Steel SA182 Type 316
6 Nozzle Inlet/Outlet	Carbon Steel A106 Gr.B	Stainless Steel SA312 Type 316
7 Lifting Lug	Carbon Steel	Stainless Steel
8 Gasket/O-Ring <sup>(2)</sup>	<b>Bolted Cover:</b> Spiral Wound Stainless Steel <b>Quick-Open:</b> Buna-N <sup>(3)</sup>	<b>Quick-Open:</b> Buna-N <sup>(3)</sup>
9 Basket Support	Carbon Steel A36 or A516-70	Stainless Steel A240 316
10 Straining Element <sup>(2)</sup>	T304 SS	T304 SS
11 Drain	Carbon Steel A105	Stainless Steel SA182 Type 316
12 Vent with Plug <sup>(4)</sup>	Carbon Steel A105	Stainless Steel SA182 Type 316
13 Studs	Carbon Steel A193 B7	Stainless Steel A193 B8 M
14 Nuts	Carbon Steel A194 2H	Stainless Steel A194 Gr.8
15 T-Bolt	Carbon Steel A325	Stainless Steel
16 T-Bolt Closure	Carbon Steel	Stainless Steel Type 316
17 Basket Support	Carbon Steel A36 or A516-70	Stainless Steel A240 316

1. Bill of Materials represents standard materials. Equivalent or better materials may be substituted at the manufacturer's discretion.  
2. Titan recommends keeping spare parts on hand.  
3. Buna-N is standard for applications below 250° F. Viton is standard for applications above 250° F.  
4. 1/2" NPT is standard.

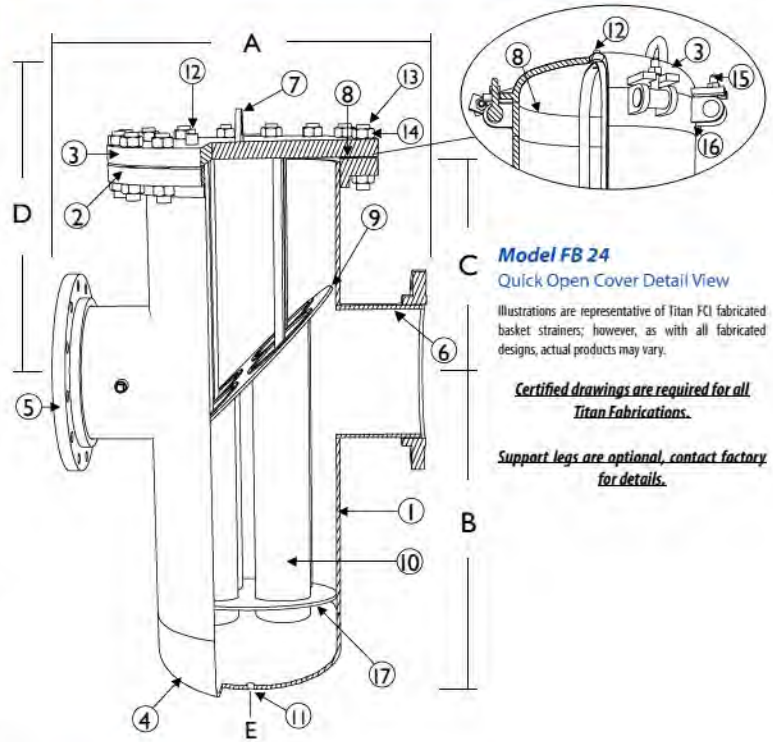

**Model FB 21**  
Bolted Cover View

**Model FB 24**  
Quick Open Cover Detail View

Illustrations are representative of Titan FCI fabricated basket strainers; however, as with all fabricated designs, actual products may vary.

**Certified drawings are required for all Titan Fabrications.**

**Support legs are optional, contact factory for details.**

**FB 20 & FB 30 Series Basket Strainer Dimensions: 12" - 48" <sup>(4)</sup> | ANSI CLASS 150, 300**

**DIMENSIONS AND WEIGHTS<sup>(1)</sup>**

	in	12	14	16	18	20	24	30	36	48
<b>A - Face to Face</b> <sup>(2)(6)</sup> FB 21, FB 24, FB 31, FB 34	mm	300	355	405	460	508	610	762	914	1219
	in	34.00	40.00	44.00	44.00	50.00	66.00	66.00	84.00	96.00
	mm	864	1016	1118	1118	1270	1676	1676	2134	2438
<b>B - Center to Bottom</b>	in	31.00	34.00	44.00	44.00	44.00	51.00	62.00	77.00	122.00
	mm	787	864	1118	1118	1118	1295	1575	1956	3099
<b>C - Center to Top</b> <sup>(3)</sup>	in	20.00	22.00	22.00	22.25	24.00	32.00	34.00	34.00	45.00
	mm	508	559	559	565	610	813	864	864	1143
<b>D - Screen Removal</b>	in	64.00	70.00	79.00	79.00	83.00	106.00	119.00	133.00	196.00
	mm	1626	1778	2006	2006	2108	2692	3023	3378	4978
<b>E - NPT</b>	in	1.50	2.00	2.00	2.00	2.00	2.00	2.00	2.00	2.00
	mm	38	50	50	50	50	50	50	50	50
<b>Approx. Weight: FB 21 Bolted (ANSI 150)</b>	lb	1025.00	1125.00	1230.00	1600.00	2300.00	4480.00	6200.00	8400.00	14100.00
	kg	465	510	558	726	1043	2032	2812	3810	6396
<b>Approx. Weight: FB 24 Quick Open (ANSI 150)</b>	lb	880.00	930.00	950.00	1300.00	1760.00	3460.00	C/F	C/F	C/F
	kg	399	422	431	590	798	1569	C/F	C/F	C/F
<b>Approx. Weight: FB 31 Bolted (ANSI 300)</b>	lb	1780.00	1850.00	2100.00	2960.00	4625.00	7500.00	C/F	C/F	C/F
	kg	807	839	953	1343	2098	3402	C/F	C/F	C/F
<b>Approx. Weight: FB 34 Quick Open (ANSI 300)</b>	lb	1425.00	1430.00	1450.00	2265.00	3220.00	5200.00	C/F	C/F	C/F
	kg	646	649	658	1028	1461	2359	C/F	C/F	C/F

1. Dimensions and weights of the FB 21, FB 24, FB 31, FB 34 are provided for reference only. Certified drawings are required for all Titan Fabrications.  
2. Face to face values have a tolerance of ±0.06 in (±2.0 mm) for sizes 10" and lower and a tolerance of ±0.12 in (±3.0 mm) for sizes 12" and larger.  
3. Centerline dimension is from the top of body flange. Does not include cover. Quick open cover dimension is to the top of body housing.

4. Smaller sizes are available. Please consult page 6 of catalog.  
5. Centerline to bottom dimension is to bottom of body housing and does not include the NPT plug.  
6. Face to face dimension listed are for flanged units only. Please call factory for more information.