

**"Y" (WYE) STRAINER ♦ ANSI CLASS 300****DUCTILE IRON ♦ THREADED ENDS****Titan Series – 12-DI****IMPROVED DESIGN...**INCREASED TEMPERATURE  
RATING PER**ASTM A395****MODEL: YS 12-DI****(DUCTILE IRON)**

1 1/4" YS 12-DI

**FEATURES**

SIZE RANGE : 1/4" ~ 3"

♦ **ENHANCED DESIGN**

IMPROVED 45° 'Y' ANGLE PROVIDES STRONGER CASTING, THUS ELIMINATING FIELD PROBLEMS. ALSO, THE NEW DUCTILE IRON MATERIAL OFFERS EXCELLENT LONG TERM ABRASION AND WEAR RESISTANCE, AND IS BETTER SUITED FOR ELEVATED TEMPERATURES PER ASTM A395.

♦ **PRECISION MACHINED SEATS**

PRECISION MACHINED SCREEN SEATS IN BOTH THE BODY AND CAP HELP TO ENSURE ACCURATE POSITIONING OF THE SCREEN DURING REASSEMBLY AFTER CLEANING. ALSO, THE MACHINED BODY SEATS ENABLE FINER FILTRATION BY PREVENTING DEBRIS BYPASS.

♦ **SELF-CLEANING CAPABILITY**

WITH A TAPPED NPT BLOW-OFF CONNECTION, THIS UNIT CAN BE FITTED WITH A BLOW-DOWN VALVE WHICH FACILITATES CLEANING OF THE STRAINING ELEMENT. PLEASE CONTACT FACTORY FOR MORE INFORMATION.

♦ **EPOXY PAINTED**

ALL UNITS ARE EPOXY PAINTED TO HELP RESIST RUST AND CORROSION.

♦ **POTABLE WATER/FDA APPROVED COATINGS AVAILABLE**

IN ADDITION TO ITS LEAD FREE, CAST IRON BODY, TITAN CAN PROVIDE NSF/ANSI AND FDA APPROVED EPOXY COATINGS WHICH MAKE THIS PRODUCT SUITABLE FOR POTABLE WATER AND FOOD CONTACT APPLICATIONS. NUMEROUS OPTIONS ARE AVAILABLE. PLEASE CONTACT US FOR MORE DETAILS.

♦ **THREADED CAP**

TITAN'S YS12 HAS STRAIGHT THREADS TO PERMIT EASY CAP REMOVAL FOR CLEANING AND PROPER ALIGNMENT WHEN REASSEMBLING STRAINER.

♦ **NATURAL GAS AND OTHER SPECIAL APPLICATIONS**

TITAN HAS EXTENSIVELY TESTED THE YS12 IN GAS APPLICATIONS AND DETERMINED THAT BUNA-N GASKETS PROVIDE SUPERB SEALING CAPABILITIES FOR THE SERVICE. ALWAYS SPECIFY IF A SPECIAL GASKET OR SCREEN IS REQUIRED FOR A SPECIFIC APPLICATION.

Lead Free,  
Ductile Iron Body**TECHNICAL**

**PRESSURE/TEMPERATURE RATING <sup>(1)</sup>**  
DUCTILE IRON - ASTM A395 - CLASS 300  
**YS 12-DI (THREADED)**

WOG (Non-Shock): 640 PSI @ 100 °F

• The above listed temperatures are theoretical and may vary during actual operating conditions.

**APPLICATIONS**

**GENERAL APPLICATION:** Y-STRAINERS ARE INSTALLED IN A PIPING SYSTEM TO REMOVE UNWANTED DEBRIS FROM THE PIPELINE, PROTECTING EXPENSIVE EQUIPMENT DOWNSTREAM SUCH AS PUMPS, METERS, SPRAY NOZZLES, COMPRESSORS, AND TURBINES. THEY CAN BE PLACED IN A HORIZONTAL OR VERTICAL PIPELINE AS LONG AS THE SCREEN IS IN A DOWNWARD POSITION. STRAINING IS ACCOMPLISHED VIA AN INTERNAL PERFORATED OR MESH LINED STRAINING ELEMENT, THE SIZE OF WHICH SHOULD BE DETERMINED BASED ON THE SIZE OF THE SMALLEST PARTICLE TO BE REMOVED.

**SERVICING:** THE STRAINING ELEMENT NEEDS REGULAR CLEANING TO PREVENT DEBRIS BUILD UP. IT IS NOT ADVISABLE TO ALLOW THE DIFFERENTIAL PRESSURE TO INCREASE BY 20 PSI. ALTHOUGH CLEANING NORMALLY REQUIRES THE REMOVAL OF THE STRAINING ELEMENT, INSTALLING AND USING A TITAN BLOW-OFF DRAIN VALVE CAN INCREASE THE TIME BETWEEN CLEANINGS.

The above data represents common market and service applications. No representation or guarantee, expressed or implied, is given due to the numerous variations of concentrations, temperatures and flow conditions that may occur during actual service.

**CHASE FILTERS**  
AND COMPONENTS

# Titan Series – 12-DI

## "Y" (WYE) STRAINER YS 12-DI - (Ductile Iron)

ANSI Class  
300

Threaded Ends • Ductile Iron • ANSI Class 300

### BILL OF MATERIALS<sup>(1)</sup>

No.	PART	YS 12-DI
1	Body <sup>(2)</sup>	Ductile Iron ASTM A395
2	Cap	Ductile Iron ASTM A395
3	Straining Element <sup>(3) (5)</sup>	Stainless Steel
4	Gasket <sup>(3) (4)</sup>	Grafoil
5	NPT Plug (Blow-off)	Steel

1. Bill of Materials represents standard materials. Equivalent or better materials may be substituted at the manufacturer's discretion.
2. All units are epoxy painted.
3. Denotes recommended spare parts.
4. Contact Titan for special gaskets materials, including Buna-N or Viton, for natural gas, hot air, or other applications.
5. Stainless Steel Straining Element is available in Type 304 and Type 316 Stainless Steel. A wide range of wire mesh and perforated screens are available. See "Standard Screen Selections" chart below for standard performances and meshes. Please specify if a non-standard screen is required.

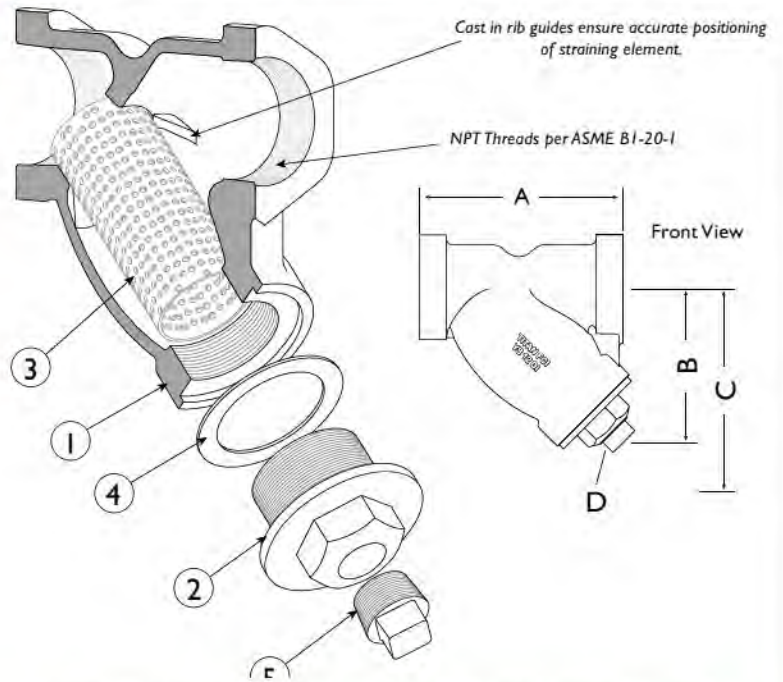

Illustrations are representative of a 2" YS12-DI. Please ask for certified drawings when required.

### DIMENSIONS AND PERFORMANCE DATA<sup>(1)</sup>

SIZE	in	1/4	3/8	1/2	3/4	1	1 1/4	1 1/2	2	2 1/2	3
	mm	8	10	15	20	25	32	40	50	65	80
<b>A DIMENSION</b> FACE TO FACE <sup>(2)</sup>	in	3.21	3.21	3.21	3.75	4.03	5.04	5.81	7.04	9.20	10.02
	mm	82	82	82	95	103	128	148	179	234	255
<b>B DIMENSION</b> CENTER LINE TO BOTTOM	in	2.10	2.10	2.10	3.04	3.52	3.71	4.25	5.67	7.25	7.25
	mm	54	54	54	77	90	94	108	144	184	184
<b>C DIMENSION</b> SCREEN REMOVAL	in	2.70	2.70	2.70	4.05	4.85	5.22	6.43	8.25	10.97	10.97
	mm	69	69	69	103	123	133	163	210	279	279
<b>D NPT Plug</b> BLOW-OFF	in	1/4	1/4	1/4	3/8	3/8	3/4	3/4	1	1 1/2	1 1/2
	mm	8	8	8	10	10	20	20	25	40	40
APPROXIMATE ASSEMBLED WEIGHT	lb	1.5	1.5	1.25	2.6	3.5	5.2	7.5	12.9	25.5	28.5
	kg	0.7	0.7	0.6	1.2	1.6	2.4	3.4	5.9	11.6	12.9
Flow Coefficient	C <sub>v</sub>	2	2	8	15	22	38	42	70	110	160

1. Dimensions and weights are for reference only. When required, request certified drawings.
2. Face to face values have a tolerance of ±0.06 in (±2.0 mm).

### PRESSURE - TEMPERATURE RATINGS<sup>(1)</sup>

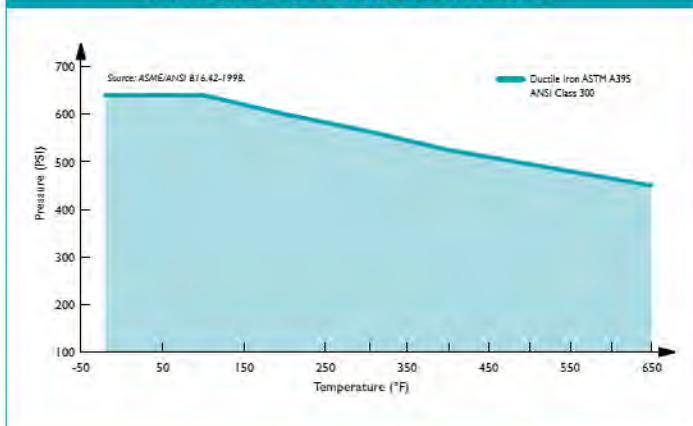

### PRESSURE - TEMPERATURE RATING

<b>ANSI CLASS 300</b>	ASTM A395
WOG (Non-Shock)	640 PSI @ 100 °F

### STANDARD SCREEN SELECTIONS

Size	Liquid	Open Area	Steam	Open Area
1/4" - 2"	20 Mesh	51.8%	30 Mesh	44.8%
2 1/2" - 3"	1/16 (.0625)	41%	3/64 (.045)	36%

### REFERENCED STANDARDS & CODES

CODE	DESCRIPTION
ASME/ANSI B16.42	Ductile Iron Pipe Flanges and Flanged Fittings