

"Y" (WYE) STRAINER ♦ ANSI CLASS 125

CAST BRONZE ♦ THREADED AND SOLDER ENDS

# Titan Series – 55/56

## MODELS: YS 55-BZ

(THREADED ENDS - BRONZE)

## YS 56-BZ

(SOLDER ENDS - BRONZE)



SIZE RANGE : 1/4" ~ 3"

## FEATURES

- ♦ **LARGE STRAINING CAPACITY**  
WITH ITS LARGE BODY AND SIZABLE STRAINING ELEMENT, THE YS55 AND YS56 PROVIDE EXCELLENT OPEN AREA RATIOS THAT ARE TYPICALLY TWO-AND-A-HALF TIMES LARGER THAN THE CORRESPONDING PIPELINE, MINIMIZING PRESSURE DROP ACROSS THE VALVE.
- ♦ **PRECISION MACHINED SEATS**  
PRECISION MACHINED SCREEN SEATS IN BOTH THE BODY AND CAP HELP TO ENSURE ACCURATE POSITIONING OF THE SCREEN DURING REASSEMBLY AFTER CLEANING. ALSO, THE MACHINED BODY SEATS ENABLE FINER FILTRATION BY PREVENTING DEBRIS BYPASS.
- ♦ **SELF-CLEANING CAPABILITY**  
WITH A TAPPED NPT BLOW-OFF CONNECTION, THIS UNIT CAN BE FITTED WITH A BLOW-DOWN VALVE WHICH FACILITATES CLEANING OF THE STRAINING ELEMENT. PLEASE CONTACT FACTORY FOR MORE INFORMATION.
- ♦ **THREADED CAP**  
TITAN'S YS55 AND YS56 HAVE STRAIGHT THREADS TO PERMIT EASY CAP REMOVAL FOR CLEANING AND PROPER ALIGNMENT WHEN REASSEMBLING STRAINER.

## TECHNICAL

PRESSURE/ TEMPERATURE RATING <sup>(1)</sup>  
BZ - C84400 - ASTM B584 - CLASS 125  
**YS 55-BZ (THREADED)**

WOG (Non-shock): 200 PSI @ 150 °F

PRESSURE/ TEMPERATURE RATING <sup>(1)</sup>  
BZ - C84400 - ASTM B584 - CLASS 125  
**YS 56-BZ (SOLDER) <sup>(2)</sup>**

WOG (Non-shock):

400 PSI @ 100 °F (1/4" - 1 1/2")  
315 PSI @ 100 °F (2" - 3")

1. The above listed temperatures are theoretical and may vary during actual operating conditions.
2. The internal working pressure rating for a solder joint strainer is dependent, not only on the strainer, but also on the composition of the solder used for the joint. The working pressure ratings shown for model YS 56-BZ (Solder) are representative of using an alloy Sb5 95-5 tin-antimony solder. For other solder joints, please consult factory.

## APPLICATIONS

**GENERAL APPLICATION:** Y-STRAINERS ARE INSTALLED IN A PIPING SYSTEM TO REMOVE UNWANTED DEBRIS FROM THE PIPELINE, PROTECTING EXPENSIVE EQUIPMENT DOWNSTREAM SUCH AS PUMPS, METERS, SPRAY NOZZLES, COMPRESSORS, AND TURBINES. THEY CAN BE PLACED IN A HORIZONTAL OR VERTICAL PIPELINE AS LONG AS THE SCREEN IS IN A DOWNWARD POSITION. STRAINING IS ACCOMPLISHED VIA AN INTERNAL PERFORATED OR MESH LINED STRAINING ELEMENT, THE SIZE OF WHICH SHOULD BE DETERMINED BASED ON THE SIZE OF THE SMALLEST PARTICLE TO BE REMOVED.

**SERVICING:** THE STRAINING ELEMENT NEEDS REGULAR CLEANING TO PREVENT DEBRIS BUILD UP. IT IS NOT ADVISABLE TO ALLOW THE DIFFERENTIAL PRESSURE TO INCREASE BY 20 PSI. ALTHOUGH CLEANING NORMALLY REQUIRES THE REMOVAL OF THE STRAINING ELEMENT, INSTALLING AND USING A TITAN BLOW-OFF DRAIN VALVE CAN INCREASE THE TIME BETWEEN CLEANINGS.

*The above data represents common market and service applications. No representation or guarantee, expressed or implied, is given due to the numerous variations of concentrations, temperatures and flow conditions that may occur during actual service.*





# Titan Series – 55/56

**"Y" (WYE) STRAINER**  
**YS 55-BZ - (Threaded)**  
**YS 56-BZ - (Solder)**  
 Threaded or Solder Ends • ANSI Class 125 • Bronze

ANSI Class  
 125

### BILL OF MATERIALS <sup>(1)</sup>

No.	PART	YS 55/56 - BZ
1	Body	Bronze (C84400) ASTM B584
2	Cap	Bronze (C84400) ASTM B584
3	Straining Element <sup>(2)</sup>	Stainless Steel
4	Gasket <sup>(2)</sup>	Teflon
5	NPT Plug (Blow-off)	Bronze (C84400) ASTM B584

1. Bill of Materials represents standard materials. Equivalent or better materials may be substituted at the manufacturer's discretion.
2. Denotes recommended spare parts.

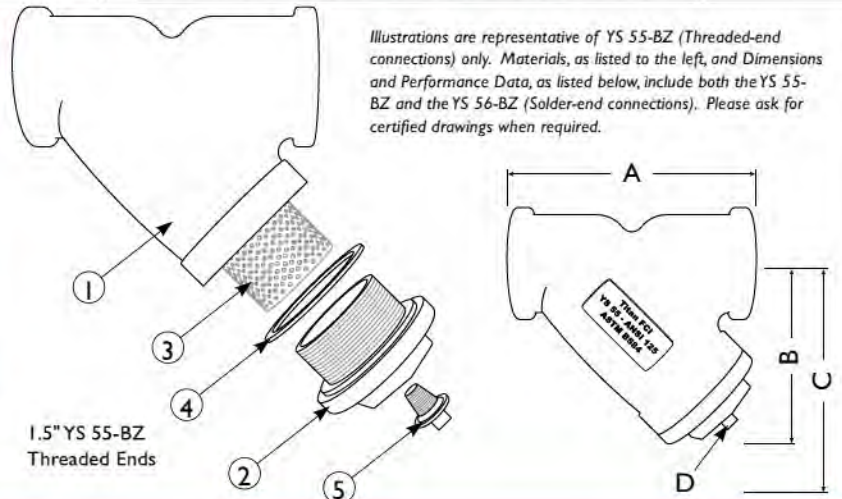

Illustrations are representative of YS 55-BZ (Threaded-end connections) only. Materials, as listed to the left, and Dimensions and Performance Data, as listed below, include both the YS 55-BZ and the YS 56-BZ (Solder-end connections). Please ask for certified drawings when required.

1.5" YS 55-BZ  
 Threaded Ends

### DIMENSIONS AND PERFORMANCE DATA <sup>(1)</sup>

SIZE	in	1/4	3/8	1/2	3/4	1	1 1/4	1 1/2	2	2 1/2	3
	mm	8	10	15	20	25	32	40	50	65	80
<b>A DIMENSION</b> FACE TO FACE (YS 55) <sup>(2)</sup>	in	C/F	2.38	2.80	3.18	3.70	4.41	4.93	5.91	C/F	10.60
	mm	C/F	61	71	81	94	112	125	150	C/F	269
<b>A DIMENSION</b> FACE TO FACE (YS 56) <sup>(2)</sup>	in	C/F	C/F	2.75	3.36	3.80	4.58	5.33	6.11	C/F	11.40
	mm	C/F	C/F	70	86	97	116	136	155	C/F	290
<b>B DIMENSION</b> CENTER LINE TO BOTTOM (YS 55)	in	C/F	1.39	1.60	1.86	2.13	2.50	2.92	3.60	C/F	5.50
	mm	C/F	36	41	48	54	64	74	92	C/F	140
<b>B DIMENSION</b> CENTER LINE TO BOTTOM (YS 56)	in	C/F	C/F	1.60	1.86	2.13	2.50	2.92	3.60	C/F	7.0
	mm	C/F	C/F	41	48	54	64	74	92	C/F	140
<b>C DIMENSION</b> SCREEN REMOVAL	in	C/F	3.75	4.0	4.25	4.75	6.0	7.0	8.0	C/F	10.0
	mm	C/F	95	102	108	121	152	178	203	C/F	254
<b>D NPT Plug</b> BLOW-OFF	in	C/F	1/4"	1/4"	1/4"	1/2"	1/2"	3/4"	1"	C/F	1"
	mm	C/F	8	8	8	15	15	20	25	C/F	25
<b>ASSEMBLED WEIGHT</b> YS 55 - THREADED (APPROXIMATE)	lb	C/F	0.35	0.45	0.85	1.30	2.00	2.65	4.30	C/F	12.90
	kg	C/F	0.16	0.21	0.39	0.6	0.91	1.21	1.95	C/F	5.85
<b>ASSEMBLED WEIGHT</b> YS 56 - SOLDER (APPROXIMATE)	lb	C/F	C/F	0.35	0.55	0.85	1.60	1.65	2.80	C/F	16.20
	kg	C/F	C/F	0.16	0.25	0.39	0.73	0.75	1.27	C/F	7.35
<b>Flow Coefficient</b>	C <sub>v</sub>		0.7	2	8	15	22	38	42	70	110

1. Dimensions and weights are for reference only. When required, request certified drawings.
2. Face to face values have a tolerance of ±0.06 in (±2.0 mm).

### PRESSURE - TEMPERATURE RATING - YS 55-BZ (Threaded)

(1/4" - 3")

WOG (Non-shock): 200 PSI @ 150 °F

### PRESSURE - TEMPERATURE RATING - YS 56-BZ (Solder) <sup>(1)</sup>

(1/4" - 1 1/2") (2" - 3")

WOG (Non-shock): 400 PSI @ 100 °F 315 PSI @ 100 °F

### STANDARD SCREEN SELECTIONS

Size	Liquid	Open Area	Steam	Open Area
1/4" ~ 2"	20 mesh	51.8%	30 mesh	44.8%
2 1/2" ~ 3"	1/16 (.0625)	41%	3/64 (.045)	36%

### REFERENCED STANDARDS & CODES

CODE	DESCRIPTION
ASME/ANSI B16.15	Cast Bronze Threaded Fittings
ASME/ANSI B16.18	Cast Copper Alloy Solder Joint Pressure Fittings
ASME/ANSI B16.50	Copper Alloy Braze-Joint Pressure Fittings

### PRESSURE - TEMPERATURE RATINGS <sup>(1)</sup>

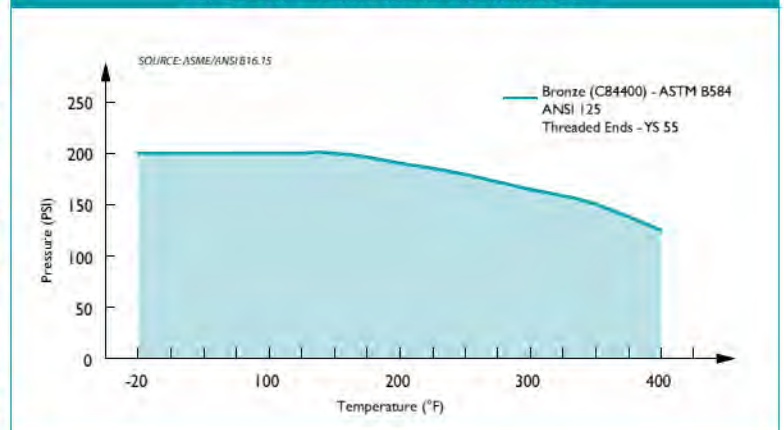

1. The pressure-temperature ratings given are ONLY for the YS 55-BZ (Threaded) per ASME B16.15. The internal working pressure rating for a solder joint strainer is dependent, not only on the strainer, but also on the composition of the solder used for the joint. The working pressure ratings shown for model YS 56-BZ (Solder) are representative of using an alloy Sb5 95-5 tin-antimony solder. For other solder joints, please consult factory.