

"Y" (WYE) STRAINER ♦ ANSI CLASS 125
CAST IRON ♦ FLANGED ENDS, FLAT FACE

Titan Series – 58

MODELS: YS 58-CI
 (CAST IRON)

**NEWLY DESIGNED...
 Gauge Taps**

STANDARD ON ALL
 YS 58-CI MODELS IN
 SIZES 2" – 20"



Lead Free,
 Cast Iron Body

FEATURES

SIZE RANGE : 2" ~ 24"

- ♦ **NEW DESIGN WITH GAUGE TAPS**
 TITAN'S YS58 HAS CONVENIENT GAUGE TAPS FURNISHED WITH A PLUG ON BOTH THE INLET AND OUTLET SIDES OF SIZES 2" THROUGH 20". THESE TAPS ALLOW FOR EASY INSTALLATION OF PRESSURE GAUGES TO MONITOR DIFFERENTIAL PRESSURE AND DETERMINE WHEN SCREEN CLEANING IS NECESSARY. ADDITIONALLY, SIZES 2" THROUGH 6" HAVE AN EXTRA BOSS FOR CUSTOM GAUGE TAPPING.
- ♦ **LARGE STRAINING CAPACITY**
 WITH ITS LARGE BODY AND SIZABLE STRAINING ELEMENT, THE YS58 PROVIDES EXCELLENT OPEN AREA RATIOS THAT ARE TYPICALLY TWO-AND-A-HALF TIMES LARGER THAN THE CORRESPONDING PIPELINE.
- ♦ **PRECISION MACHINED SEATS**
 PRECISION MACHINED SCREEN SEATS IN BOTH THE BODY AND CAP HELP TO ENSURE ACCURATE POSITIONING OF THE SCREEN DURING REASSEMBLY AFTER CLEANING. ALSO, THE MACHINED BODY SEATS ENABLE FINER FILTRATION BY PREVENTING DEBRIS BYPASS.
- ♦ **SELF-CLEANING CAPABILITY**
 WITH A TAPPED NPT BLOW-OFF CONNECTION, THIS UNIT CAN BE FITTED WITH A BLOW-DOWN VALVE WHICH FACILITATES CLEANING OF THE STRAINING ELEMENT. PLEASE CONTACT FACTORY FOR MORE INFORMATION.
- ♦ **EPOXY PAINTED**
 ALL UNITS ARE EPOXY PAINTED TO HELP RESIST RUST AND CORROSION.
- ♦ **POTABLE WATER/FDA APPROVED COATINGS AVAILABLE**
 IN ADDITION TO ITS LEAD FREE, CAST IRON BODY, TITAN CAN PROVIDE NSF/ANSI AND FDA APPROVED EPOXY COATINGS WHICH MAKE THIS PRODUCT SUITABLE FOR POTABLE WATER AND FOOD CONTACT APPLICATIONS. NUMEROUS OPTIONS ARE AVAILABLE. PLEASE CONTACT US FOR MORE DETAILS.
- ♦ **OPTIONAL COVER DESIGNS**
 TITAN'S YS58 IS AVAILABLE WITH DIFFERENT COVER OPTIONS INCLUDING SWING, CLAMP, AND HINGE TYPE COVERS. PLEASE CONSULT FACTORY FOR MORE INFORMATION ON THESE OPTIONS.

TECHNICAL

PRESSURE/TEMPERATURE RATING
 CI-ASTM A126 GR. B - CLASS 125
 SIZES 2" ~ 12"

WOG (Non-shock): 200 PSI @ 150 °F

PRESSURE/TEMPERATURE RATING
 CI-ASTM A126 GR. B - CLASS 125
 SIZES 14" ~ 24"

WOG (Non-shock): 150 PSI @ 150 °F

- The above listed temperatures are theoretical and may vary during actual operating conditions.

APPLICATIONS

GENERAL APPLICATION: Y-STRAINERS ARE INSTALLED IN A PIPING SYSTEM TO REMOVE UNWANTED DEBRIS FROM THE PIPELINE, PROTECTING EXPENSIVE EQUIPMENT DOWNSTREAM SUCH AS PUMPS, METERS, SPRAY NOZZLES, COMPRESSORS, AND TURBINES. THEY CAN BE PLACED IN A HORIZONTAL OR VERTICAL PIPELINE AS LONG AS THE SCREEN IS IN A DOWNWARD POSITION. STRAINING IS ACCOMPLISHED VIA AN INTERNAL PERFORATED OR MESH LINED STRAINING ELEMENT, THE SIZE OF WHICH SHOULD BE DETERMINED BASED ON THE SIZE OF THE SMALLEST PARTICLE TO BE REMOVED.

SERVICING: THE STRAINING ELEMENT NEEDS REGULAR CLEANING TO PREVENT DEBRIS BUILD UP. IT IS NOT ADVISABLE TO ALLOW THE DIFFERENTIAL PRESSURE TO INCREASE BY 20 PSI. ALTHOUGH CLEANING NORMALLY REQUIRES THE REMOVAL OF THE STRAINING ELEMENT, INSTALLING AND USING A TITAN BLOW-OFF DRAIN VALVE CAN INCREASE THE TIME BETWEEN CLEANINGS.

The above data represents common market and service applications. No representation or guarantee, expressed or implied, is given due to the numerous variations of concentrations, temperatures and flow conditions that may occur during actual service.

CHASE FILTERS
 AND COMPONENTS

Titan Series – 58

"Y" (WYE) STRAINER YS 58-CI - (Cast Iron)

ANSI Class
125

Flanged Ends • Flat Face • Cast Iron

BILL OF MATERIALS⁽¹⁾

No.	PART	YS 58-CI
1	Body	Cast Iron A126 Gr. B
2	Cover	Cast Iron A126 Gr. B
3	Straining Element ⁽²⁾	Stainless Steel
4	Gasket ⁽²⁾	Non-Asbestos Gasket, Garlock 3000 or Equal
5	Cap Screws	Steel
6	NPT Plug (Blow-off)	Carbon Steel
7	NPT Plugs (Gauge Taps) ⁽²⁾	Carbon Steel

1. Bill of Materials represents standard materials. Equivalent or better materials may be substituted at the manufacturer's discretion.
2. Denotes recommended spare parts.
3. Gauge taps and NPT Plugs (Part #7) are standard only on sizes 2" through 20". See Dimensions and Performance Data for the standard NPT sizes.

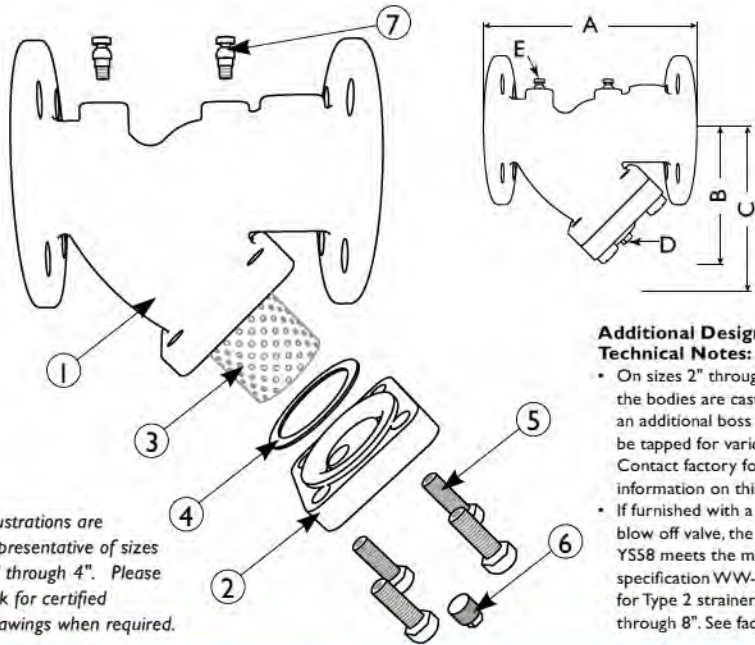

Illustrations are representative of sizes 2" through 4". Please ask for certified drawings when required.

- Additional Design and Technical Notes:**
- On sizes 2" through 6", the bodies are cast with an additional boss that can be tapped for various sizes. Contact factory for more information on this option.
 - If furnished with a bronze blow off valve, the YS58 meets the military specification WW-S-2739 for Type 2 strainers, sizes 2" through 8". See factory.

DIMENSIONS AND PERFORMANCE DATA⁽¹⁾

SIZE	in	2	2 1/2	3	4	5	6	8	10	12	14	16	18	20	24
	mm	50	65	80	100	125	150	200	250	300	350	400	450	500	600
A DIMENSION FACE TO FACE (FLAT FACE) ⁽²⁾	in	7.875	10.0	10.125	12.12	15.62	18.5	21.625	25.75	29.87	33.25	38.75	43.125	49.5	58.375
	mm	200	254	256	308	397	470	550	655	759	845	984	1095	1257	1483
B DIMENSION CENTER LINE TO BOTTOM	in	5.25	6.50	7.0	8.25	11.25	13.5	15.5	18.5	21.75	25.0	26.5	31.0	39.0	45.0
	mm	133	166	178	210	286	343	394	470	553	625	673	787	991	1143
C DIMENSION SCREEN REMOVAL	in	7.0	9.75	10.0	12.0	20.0	20.0	22.75	28.0	30.0	36.5	42.0	45.5	56.0	68.0
	mm	178	248	254	305	508	508	578	712	762	927	1067	1156	1422	1727
D NPT Plug BLOW-OFF	in	1/2	1	1	1 1/2	2	2	2	2	2	2	2	2	2	2
	mm	15	25	25	40	50	50	50	50	50	50	50	50	50	50
E NPT Plug GAUGETAPS	in	1/4	1/4	1/4	1/4	1/4	1/4	1/4	1/4	1/4	1/4	1/4	1/4	1/4	n/a
	mm	8	8	8	8	8	8	8	8	8	8	8	8	8	n/a
APPROXIMATE ASSEMBLED WEIGHT	lb	20.0	33.0	34.0	60.0	105.0	130.0	236.0	338.0	554.0	828.0	1130.0	1692.0	1888.0	3000.0
	kg	9.1	15.0	15.4	27.2	47.6	59.0	107.1	153.3	259.3	375.6	512.6	767.5	856.4	1360.8
Flow Coefficient	C _v	70	110	160	260	400	570	950	1600	2200	3300	4900	6100	8000	11000

1. Dimensions and weights are for reference only. When required, request certified drawings.
2. Face to face values have a tolerance of ±0.06 in (±2.0 mm) for sizes 10" and lower and a tolerance of ±0.12 in (±3.0 mm) for sizes 12" and larger.

PRESSURE - TEMPERATURE RATINGS⁽¹⁾

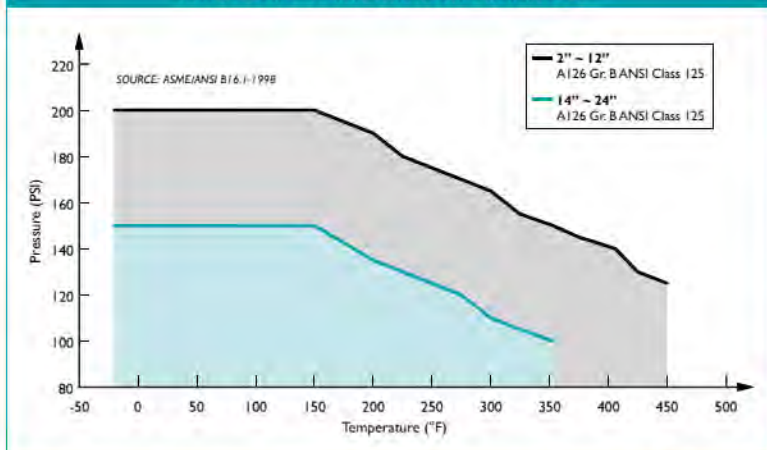

1. This chart displays the pressure-temperature ratings for the valve's body per ASME B16.1-1998.

Titan FCI makes every effort to ensure the information presented on our literature accurately reflects exact product specifications. However, as product changes occur, there may be short-term differences between actual product specifications and the information contained within our literature. Titan FCI reserves the right to make design and specification changes to improve our products without prior notification. When required, request certified drawings.

PRESSURE - TEMPERATURE RATING

A126 Gr. B	2" ~ 12"	14" ~ 24"
WOG (Non-shock):	200 PSI @ 150 °F	150 PSI @ 150 °F

STANDARD SCREEN SELECTIONS

Size	Liquid	Open Area	Steam	Open Area
2" ~ 4"	1/16 (.0625)	41%	3/64 (.045)	36%
5" ~ 8"	1/8 (.125)	40%	3/64 (.045)	36%
10" ~ 16" ⁽¹⁾	1/8 (.125)	40%	30 Mesh Lined	44.8%

1. Please consult factory for screen selections on 18" and larger YS 58-CI models.

REFERENCED STANDARDS & CODES

CODE	DESCRIPTION
ASME/ANSI B16.1	Cast Iron Pipe Flanges and Flanged Fittings