

"Y" (WYE) STRAINER ♦ STAINLESS STEEL**800 WOG ♦ THREADED AND SOCKET WELD ENDS**

Titan Series – 80

MODELS: YS 80T-SS

(THREADED ENDS - STAINLESS STEEL)

YS 80S-SS

(SOCKET WELD ENDS - STAINLESS STEEL)



3" YS 80S-SS

SIZE RANGE : 1/4" ~ 4"

FEATURES

- ♦ **LARGE STRAINING CAPACITY**
WITH ITS LARGE BODY AND SIZABLE STRAINING ELEMENT, THE YS80T AND YS80S PROVIDE EXCELLENT OPEN AREA RATIOS THAT ARE TYPICALLY TWO-AND-A-HALF TIMES LARGER THAN THE CORRESPONDING PIPELINE, MINIMIZING PRESSURE DROP ACROSS THE VALVE.
- ♦ **PRECISION MACHINED SEATS**
PRECISION MACHINED SCREEN SEATS IN BOTH THE BODY AND CAP HELP TO ENSURE ACCURATE POSITIONING OF THE SCREEN DURING REASSEMBLY AFTER CLEANING. ALSO, THE MACHINED BODY SEATS ENABLE FINER FILTRATION BY PREVENTING DEBRIS BYPASS.
- ♦ **SELF-CLEANING CAPABILITY**
WITH A TAPPED NPT BLOW-OFF CONNECTION, THIS UNIT CAN BE FITTED WITH A BLOW-DOWN VALVE WHICH FACILITATES CLEANING OF THE STRAINING ELEMENT. PLEASE CONTACT FACTORY FOR MORE INFORMATION.
- ♦ **THREADED CAP**
TITAN'S YS80T AND YS80S HAVE STRAIGHT THREADS TO PERMIT EASY CAP REMOVAL FOR CLEANING AND PROPER ALIGNMENT WHEN REASSEMBLING STRAINER.

TECHNICAL

PRESSURE/TEMPERATURE RATING ⁽¹⁾
SS - ASTM A351 GR. CF8M
YS 80T-SS (THREADED)

WOG (Non-shock): 800 PSI @ 100 °F

PRESSURE/TEMPERATURE RATING ⁽¹⁾
SS - ASTM A351 GR. CF8M
YS 80S-SS (SOCKET WELD)

WOG (Non-shock): 800 PSI @ 100 °F

1. The above listed temperatures are theoretical and may vary during actual operating conditions.

APPLICATIONS

GENERAL APPLICATION: Y-STRAINERS ARE INSTALLED IN A PIPING SYSTEM TO REMOVE UNWANTED DEBRIS FROM THE PIPELINE, PROTECTING EXPENSIVE EQUIPMENT DOWNSTREAM SUCH AS PUMPS, METERS, SPRAY NOZZLES, COMPRESSORS, AND TURBINES. THEY CAN BE PLACED IN A HORIZONTAL OR VERTICAL PIPELINE AS LONG AS THE SCREEN IS IN A DOWNWARD POSITION. STRAINING IS ACCOMPLISHED VIA AN INTERNAL PERFORATED OR MESH LINED STRAINING ELEMENT, THE SIZE OF WHICH SHOULD BE DETERMINED BASED ON THE SIZE OF THE SMALLEST PARTICLE TO BE REMOVED.

SERVICING: THE STRAINING ELEMENT NEEDS REGULAR CLEANING TO PREVENT DEBRIS BUILD UP. IT IS NOT ADVISABLE TO ALLOW THE DIFFERENTIAL PRESSURE TO INCREASE BY 20 PSI. ALTHOUGH CLEANING NORMALLY REQUIRES THE REMOVAL OF THE STRAINING ELEMENT, INSTALLING AND USING A TITAN BLOW-OFF DRAIN VALVE CAN INCREASE THE TIME BETWEEN CLEANINGS.

The above data represents common market and service applications. No representation or guarantee, expressed or implied, is given due to the numerous variations of concentrations, temperatures and flow conditions that may occur during actual service.



Titan Series – 80

"Y" (WYE) STRAINER YS 80T-SS - (Threaded) YS 80S-SS - (Socket Weld)

Threaded or Socket Weld • 800 WOG • Stainless Steel

Working Pressure:
800 PSI

BILL OF MATERIALS ⁽¹⁾

No.	PART	YS 80T - SS	YS 80S - SS
1	Body	ASTM A351 Gr. CF8M Type 316	ASTM A351 Gr. CF8M Type 316
2	Bonnet	ASTM A351 Gr. CF8M Type 316	ASTM A351 Gr. CF8M Type 316
3	Straining Element ⁽²⁾	Stainless Steel	Stainless Steel
4	Gasket ⁽²⁾	PTFE	PTFE
5	NPT Plug	Stainless Steel	Stainless Steel

1. Bill of Materials represents standard materials. Equivalent or better materials may be substituted at the manufacturer's discretion.
2. Denotes recommended spare parts.
3. Contact factory for more information.

Illustrations are representative of YS 80S-SS (Socket Weld end connections) only. Materials, as listed to the left, and Dimensions and Performance Data, as listed below, include both the YS 80S-SS and the YS 80T-SS (Threaded end connections). Please ask for certified drawings when required.

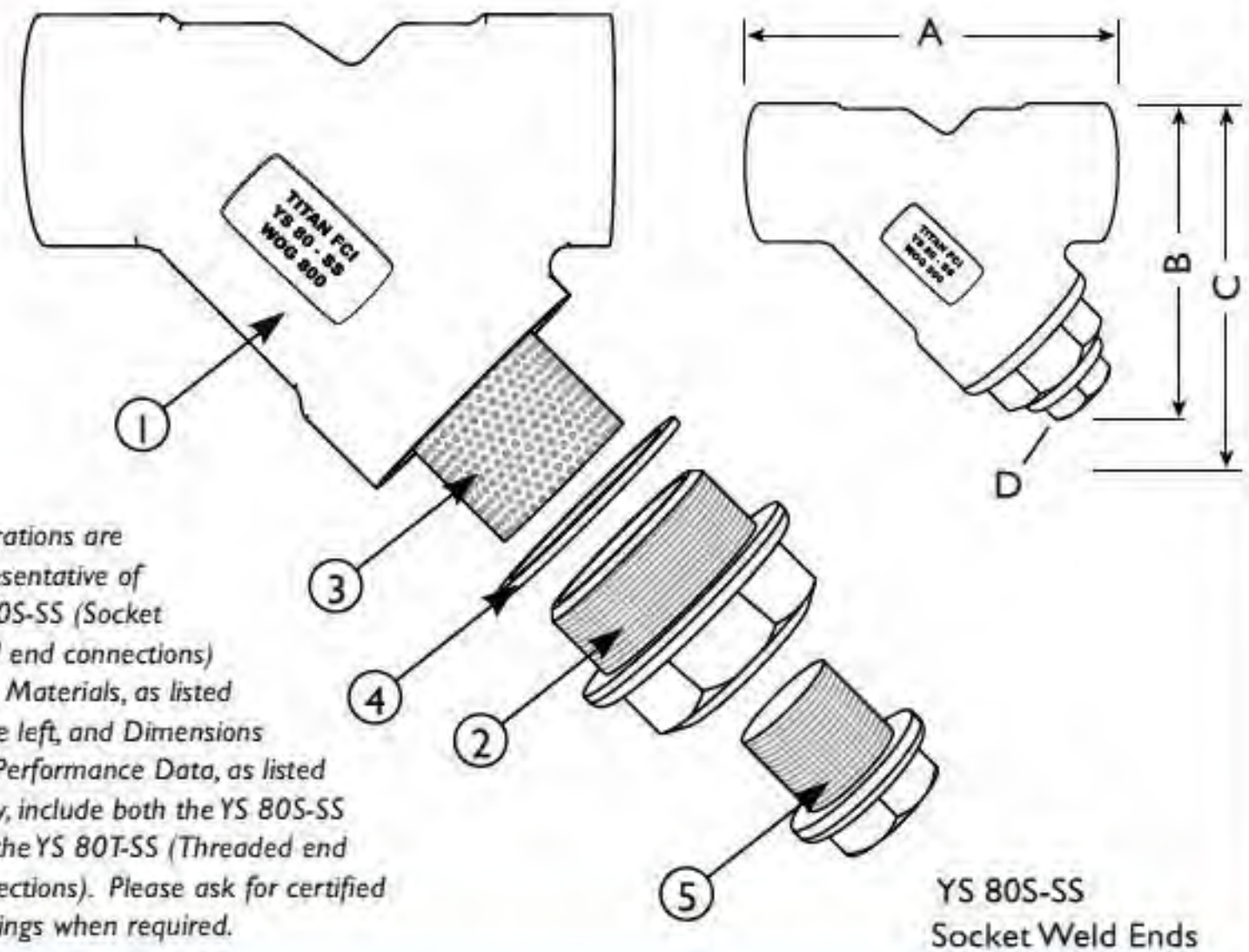

DIMENSIONS AND PERFORMANCE DATA ⁽¹⁾

SIZE	in	1/4	3/8	1/2	3/4	1	1 1/4	1 1/2	2	2 1/2	3	4
	mm	8	10	15	20	25	32	40	50	65	80	100
A DIMENSION FACE TO FACE (YS 80T) ⁽²⁾	in	2.55	2.55	2.55	3.14	3.54	4.13	4.72	5.50	6.69	7.67	9.44
	mm	65	65	65	80	90	105	120	140	170	195	240
A DIMENSION FACE TO FACE (YS 80S) ⁽²⁾	in	n/a	n/a	2.55	3.14	3.54	4.13	4.72	5.51	n/a	7.67	9.44
	mm	n/a	n/a	65	80	90	105	120	140	n/a	195	240
B DIMENSION CENTER LINE TO BOTTOM (YS 80T)	in	1.57	1.57	2.00	2.36	2.83	3.03	3.42	4.06	4.76	5.39	6.65
	mm	40	40	51	60	72	77	87	103	121	137	169
B DIMENSION CENTER LINE TO BOTTOM (YS 80S)	in	n/a	n/a	2.00	2.36	2.83	3.03	3.42	4.05	n/a	5.39	6.65
	mm	n/a	n/a	51	60	72	77	87	103	n/a	137	169
C DIMENSION SCREEN REMOVAL	in	2.00	2.00	2.50	3.25	3.75	4.25	4.75	5.50	6.50	8.00	C/F
	mm	51	51	64	83	95	108	120	140	165	203	C/F
D DIMENSION NPT PLUG (BLOW OFF)	in	1/4	1/4	1/4	3/8	3/8	3/4	3/4	1	1	1 1/4	C/F
	mm	8	8	8	10	10	20	20	25	25	32	C/F
APPROXIMATE ASSEMBLED WEIGHT	lb	0.5	0.5	0.5	1.0	1.5	2.0	2.5	4.0	6.5	9.0	C/F
	kg	0.2	0.2	0.2	0.5	0.7	0.9	1.1	1.8	2.9	4.1	C/F
Flow Coefficient	C _v	7	7	9.4	18	30	45	63	98	130	180	C/F

1. Dimensions and weights are for reference only. When required, request certified drawings.
2. Face to face values have a tolerance of ±0.06 in (±2.0 mm).

PRESSURE - TEMPERATURE RATINGS

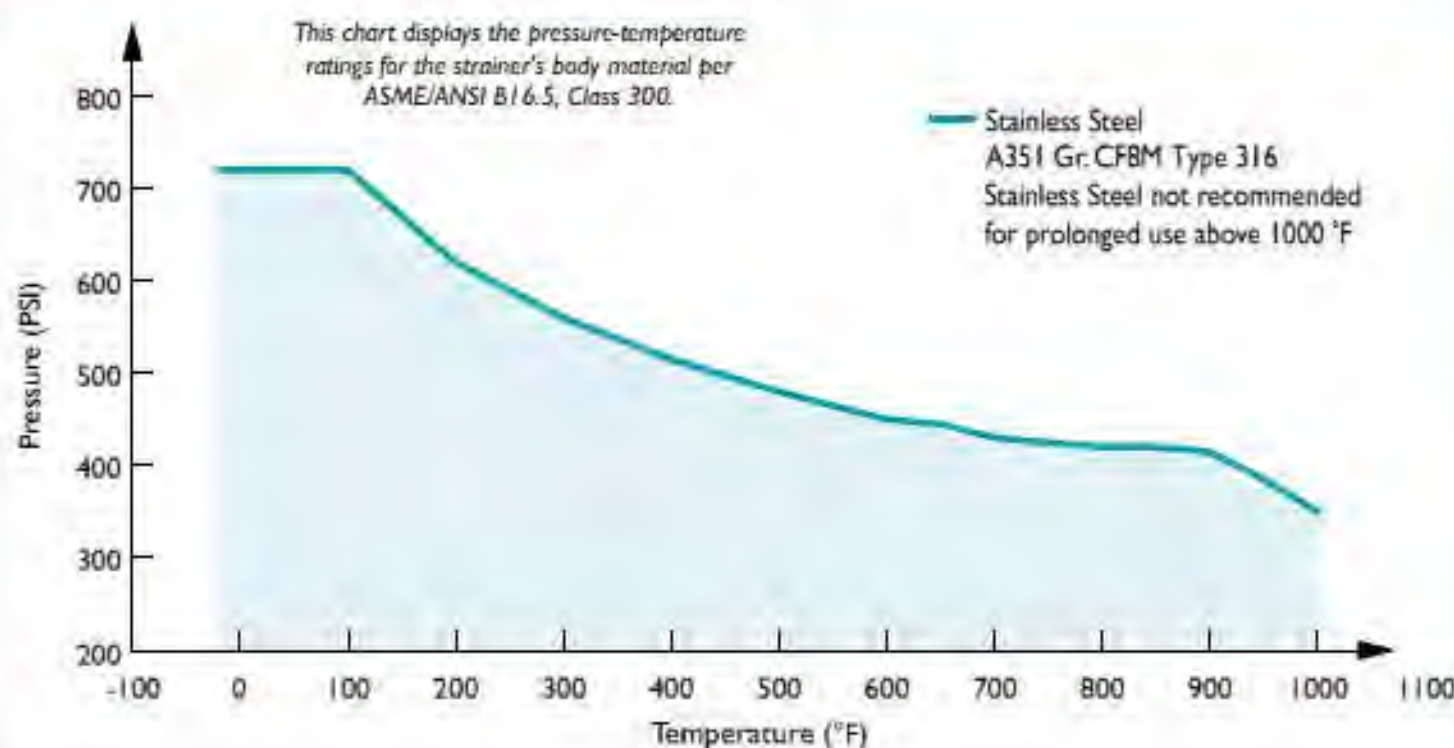

PRESSURE - TEMPERATURE RATING

Stainless Steel	YS 80T (Threaded)	YS 80S (Socket Weld)
WOG (Non-shock):	800 PSI @ 100°F	800 PSI @ 100°F

STANDARD SCREEN SELECTIONS

Size	Liquid	Open Area	Steam	Open Area
1/4" - 4"	1/16 (.0625)	41%	1/32 (.033)	28%

REFERENCED STANDARDS & CODES

CODE	DESCRIPTION
ASME/ANSI B16.34	Valves - Flanged, Threaded, and Welding End
ASME/ANSI B16.11	Forged Steel Fittings, Socket-Welding and Threaded
ASME/ANSI B1.20.1	National Pipe Thread Taper