

**"Y" (WYE) STRAINER ♦ THREADED AND SOCKET WELD****ANSI CLASS 1500 ♦ CARBON AND STAINLESS STEEL****Titan Series – 83/84****MODELS: YS 83-CS**  
(CARBON STEEL - THREADED)**YS 84-CS**  
(CARBON STEEL - SOCKET WELD)**YS 83-SS**  
(STAINLESS STEEL - THREADED)**YS 84-SS**  
(STAINLESS STEEL - SOCKET WELD)

SIZES: ½" ~ 3"

**FEATURES**

- ♦ **RUGGED - HIGH QUALITY DESIGN**  
TITAN'S YS83 AND YS84 ARE IDEAL FOR PETROCHEMICAL AND OTHER DEMANDING INDUSTRIAL APPLICATIONS THAT HAVE HIGHER PRESSURE AND TEMPERATURE REQUIREMENTS. THEY ARE DUAL RATED FOR ANSI CLASS 600 AND 1500.
- ♦ **LARGE STRAINING CAPACITY**  
WITH ITS LARGE BODY AND SIZABLE STRAINING ELEMENT, THE YS83 AND YS84 PROVIDE EXCELLENT OPEN AREA RATIOS THAT ARE TYPICALLY TWO-AND-A-HALF TIMES LARGER THAN THE CORRESPONDING PIPELINE.
- ♦ **PRECISION MACHINED SEATS**  
PRECISION MACHINED SCREEN SEATS IN BOTH THE BODY AND CAP HELP TO ENSURE ACCURATE POSITIONING OF THE SCREEN DURING REASSEMBLY AFTER CLEANING. ALSO, THE MACHINED BODY SEATS ENABLE FINER FILTRATION BY PREVENTING DEBRIS BYPASS.
- ♦ **ENCAPSULATED "CG" STYLE GASKET**  
THE "CG" STYLE COVER GASKET PROVIDES ADDITIONAL RADIAL STRENGTH TO PREVENT GASKET BLOWOUT. IT ALSO ACTS AS A COMPRESSION STOP.
- ♦ **SELF-CLEANING CAPABILITY**  
WITH THE OPTIONAL SOCKET WELD BLOW-OFF CONNECTION, THIS UNIT CAN BE FITTED WITH A BLOW-DOWN VALVE WHICH FACILITATES CLEANING OF THE STRAINING ELEMENT. PLEASE CONTACT FACTORY FOR MORE INFORMATION.
- ♦ **EPOXY PAINTED**  
CARBON UNITS ARE EPOXY PAINTED TO HELP RESIST RUST AND CORROSION. TITAN FCI ALSO OFFERS EPOXY COATING. PLEASE CONTACT FACTORY FOR MORE INFORMATION.

**TECHNICAL****PRESSURE/TEMPERATURE RATING**  
CS - ASTM A216 GR. WCB - CLASS 1500

WOG (Non-shock): 3705 PSI @ 100 °F

**PRESSURE/TEMPERATURE RATING**  
SS - ASTM A351 GR. CF8M - CLASS 1500

WOG (Non-shock): 3600 PSI @ 100 °F

- The above listed temperatures are theoretical and may vary during actual operating conditions.
- Carbon Steel not recommended for prolonged use above 800 °F.
- Stainless Steel not recommended for prolonged use above 1000 °F.

**APPLICATIONS**

**CARBON STEEL PROPERTIES:** CARBON STEEL PERFORMS EXCEPTIONALLY WELL IN HIGH TEMPERATURES, UP TO 800°F IN CONTINUOUS SERVICE. IT PROVIDES HIGH RESISTANCE TO SHOCK, VIBRATION, PIPING STRAINS, AND FIRE AND FREEZING HAZARDS. CARBON STEEL STRAINERS ARE OFTEN USED IN THE OIL AND PETROCHEMICAL INDUSTRIES

**STAINLESS STEEL PROPERTIES:** STAINLESS STEEL IS COMMONLY SPECIFIED FOR HIGH TEMPERATURE SERVICE, UP TO 1000°F IN CONTINUOUS SERVICE. STAINLESS STEEL STRAINERS ARE COMMONLY FOUND IN THE CHEMICAL, FOOD, AND PHARMACEUTICAL INDUSTRIES.

*The above data represents common market and service applications. No representation or guarantee, expressed or implied, is given due to the numerous variations of concentrations, temperatures and flow conditions that may occur during actual service.*

**CHASE FILTERS**  
AND COMPONENTS



# Titan Series – 83/84

## WYE STRAINER

Threaded Ends	Socket Weld Ends
<b>YS 83-CS</b> (Carbon Steel)	<b>YS 84-CS</b> (Carbon Steel)
<b>YS 83-SS</b> (Stainless Steel)	<b>YS 84-SS</b> (Stainless Steel)

ANSI Class  
1500

### BILL OF MATERIALS <sup>(1)</sup>

No.	PART	YS 83/84-CS <sup>(2)</sup>	YS 83/84-SS
1	Body	Carbon Steel A216 Gr. WCB	Stainless Steel A351 Gr. CF8M
2	Cover	Carbon Steel A216 Gr. WCB	Stainless Steel A351 Gr. CF8M
3	Straining Element <sup>(2)</sup>	Stainless Steel	Stainless Steel
4	Gasket <sup>(2)</sup>	Stainless Steel CG Style	Stainless Steel CG Style
5	Studs	Alloy Steel	Alloy Steel
6	Nuts	Alloy Steel	Alloy Steel

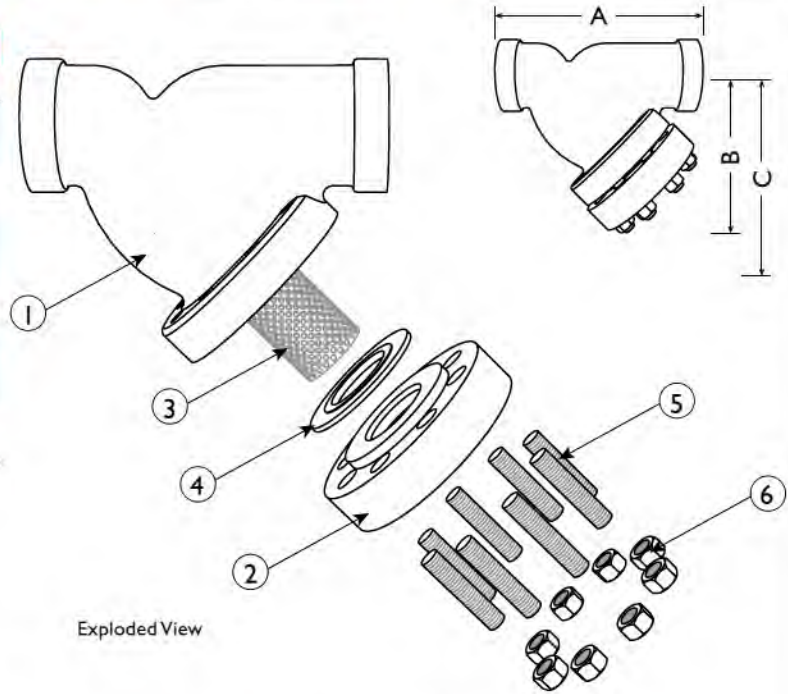

Exploded View

1. Bill of Materials represents standard materials. Equivalent or better materials may be substituted at the manufacturer's discretion.
2. Denotes recommended spare parts.
3. Carbon Steel bodies are epoxy painted.

### Additional Design & Technical Notes:

- The YS 83 and YS 84 are dual rated for ANSI Class 900 and ANSI Class 1500
- NPT blow-offs are not recommended for ANSI Class 1500 strainers. An optional socket weld blow-off is available. Contact factory for details.
- A wide range of optional gasket materials are available.
- Bodies are also available in high temperature steel A217 Gr. WC6, WC9, and other materials. Please contact factory for price and delivery.

Illustrations are representative of sizes 1/2" through 3".  
Please ask for certified drawings when required.

### DIMENSIONS AND PERFORMANCE DATA <sup>(1)</sup>

SIZE	in	1/2	3/4	1	1 1/4	1 1/2	2	2 1/2 <sup>(3)</sup>	3 <sup>(3)</sup>
	mm	15	20	25	32	40	50	65	80
<b>A DIMENSION</b> FACE TO FACE <sup>(2)</sup>	in	3.94	4.25	6.00	8.37	8.37	10.50	C/F	C/F
	mm	101	108	153	213	213	267	C/F	C/F
<b>B DIMENSION</b> CENTER LINE TO BOTTOM	in	3.00	3.75	5.75	5.50	5.50	9.25	C/F	C/F
	mm	77	96	147	140	140	235	C/F	C/F
<b>C DIMENSION</b> SCREEN REMOVAL	in	4.25	5.25	7.00	8.00	8.00	11.00	C/F	C/F
	mm	108	134	178	204	204	280	C/F	C/F
APPROXIMATE ASSEMBLED WEIGHT	lb	4.5	8.0	12.0	27.0	26.5	44.5	96.0	104.0
	kg	2.0	3.7	5.4	12.2	12.0	20.2	43.5	47.2
Flow Coefficient	C <sub>v</sub>	6	11	16	32	34	60	140	140

1. Dimensions and weights are for reference only. When required, request certified drawings.
2. Face to face values have a tolerance of ±0.06 in (±2.0 mm) for sizes 10" and lower.
3. Contact factory before ordering a 2-1/2" or 3" to get dimensions and performance data.

### PRESSURE - TEMPERATURE RATINGS

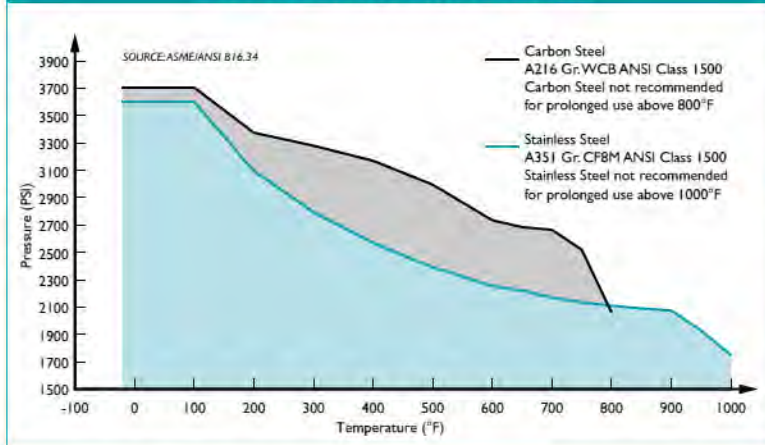

### REFERENCED STANDARDS & CODES

CODE	DESCRIPTION
ASME/ANSI B16.11	Forged Steel Fittings, Socket-Welding & Threaded
ASME/ANSI B16.34	Flanged, Threaded, and Welding End

### STANDARD SCREEN SELECTIONS

Size	Liquid	Open Area	Steam	Open Area
1/2" – 3"	1/16 (.0625)	41%	1/32 (.033)	28%

### PRESSURE - TEMPERATURE RATING

Body Material	A216 Gr. WCB	A351 Gr. CF8M
WOG (Non-shock):	3705 PSI @ 100 °F	3600 PSI @ 100 °F